

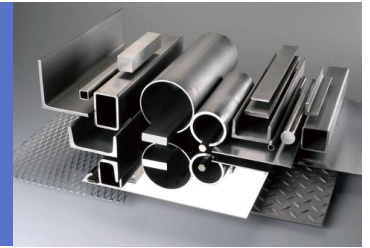

Aluminum Tube Stock List



Product Catalog

Chalco offers a wide range of 6061 aluminum tubes, including round tubes, seamless tubes, and forged tubes, ensuring consistent quality and reliability. We support small-batch orders and provide quick, efficient service for both spot and custom products.

6061 T6 Aluminum round pipe tube.....	1
6061 T6 Seamless aluminum pipe tube.....	16
6061 T6 Seamless forged aluminum pipe.....	31



Aluminum Tube Stock List

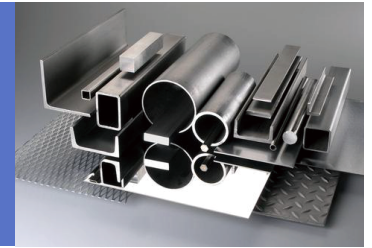

6061 T6 Aluminum round pipe tube

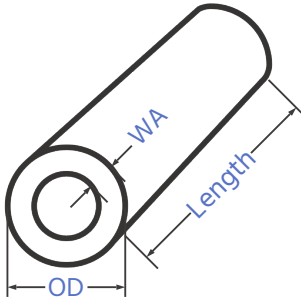

Specs: ASTM B221, ASTM B241, ASTM B429

Imperial Unit			Unit Weight		International Unit		
OD/in	Wall/in	Length/in	Lbs/FT	Kg/m	OD/mm	Wall/mm	Length/mm
0.787	0.197	157.480	0.427	0.636	20	5	4000
0.866	0.197	157.480	0.484	0.721	22	5	4000
0.945	0.197	157.480	0.541	0.806	24	5	4000
0.984	0.197	157.480	0.569	0.848	25	5	4000
0.984	0.276	157.480	0.717	1.069	25	7	4000
0.984	0.315	157.480	0.774	1.154	25	8	4000
0.984	0.394	157.480	0.854	1.272	25	10	4000
1.024	0.197	157.480	0.598	0.891	26	5	4000
1.024	0.276	118.110	0.757	1.128	26	7	3000
1.063	0.197	157.480	0.626	0.933	27	5	4000
1.102	0.197	157.480	0.655	0.975	28	5	4000
1.102	0.276	157.480	0.837	1.247	28	7	4000
1.181	0.197	157.480	0.711	1.060	30	5	4000
1.181	0.236	157.480	0.820	1.221	30	6	4000
1.181	0.276	157.480	0.916	1.366	30	7	4000
1.181	0.394	157.480	1.138	1.696	30	10	4000

Imperial Unit			Unit Weight		International Unit		
OD/in	Wall/in	Length/in	Lbs/FT	Kg/m	OD/mm	Wall/mm	Length/mm
1.260	0.197	157.480	0.768	1.145	32	5	4000
1.260	0.276	157.480	0.996	1.484	32	7	4000
1.339	0.197	157.480	0.825	1.230	34	5	4000
1.378	0.197	157.480	0.854	1.272	35	5	4000
1.378	0.236	157.480	0.990	1.476	35	6	4000
1.378	0.276	157.480	1.116	1.663	35	7	4000
1.378	0.315	157.480	1.229	1.832	35	8	4000
1.378	0.492	157.480	1.601	2.386	35	13	4000
1.417	0.197	157.480	0.882	1.315	36	5	4000
1.496	0.197	157.480	0.939	1.400	38	5	4000
1.496	0.276	157.480	1.235	1.841	38	7	4000
1.496	0.394	157.480	1.594	2.375	38	10	4000
1.575	0.197	157.480	0.996	1.484	40	5	4000
1.575	0.236	157.480	1.161	1.730	40	6	4000
1.575	0.276	157.480	1.315	1.959	40	7	4000
1.575	0.315	157.480	1.457	2.171	40	8	4000
1.575	0.394	157.480	1.707	2.545	40	10	4000
1.614	0.512	157.480	2.072	3.088	41	13	4000
1.654	0.197	157.480	1.053	1.569	42	5	4000
1.654	0.236	157.480	1.229	1.832	42	6	4000
1.654	0.276	157.480	1.394	2.078	42	7	4000
1.654	0.315	157.480	1.548	2.307	42	8	4000
1.772	0.197	157.480	1.138	1.696	45	5	4000
1.772	0.236	157.480	1.332	1.985	45	6	4000
1.772	0.276	157.480	1.514	2.256	45	7	4000
1.772	0.394	157.480	1.992	2.969	45	10	4000
1.890	0.197	157.480	1.224	1.824	48	5	4000

Imperial Unit			Unit Weight		International Unit		
OD/in	Wall/in	Length/in	Lbs/FT	Kg/m	OD/mm	Wall/mm	Length/mm
1.890	0.276	157.480	1.633	2.434	48	7	4000
1.890	0.394	157.480	2.163	3.223	48	10	4000
1.969	0.197	157.480	1.281	1.909	50	5	4000
1.969	0.276	157.480	1.713	2.553	50	7	4000
1.969	0.394	157.480	2.277	3.393	50	10	4000
1.969	0.591	236.220	2.988	4.453	50	15	6000
2.047	0.197	157.480	1.337	1.993	52	5	4000
2.047	0.433	118.110	2.567	3.826	52	11	3000
2.126	0.236	157.480	1.639	2.443	54	6	4000
2.126	0.591	157.480	3.329	4.962	54	15	4000
2.165	0.118	129.921	0.888	1.323	55	3	3300
2.165	0.197	157.480	1.423	2.121	55	5	4000
2.165	0.276	157.480	1.912	2.850	55	7	4000
2.165	0.335	157.480	2.250	3.353	55	9	4000
2.165	0.394	236.220	2.561	3.817	55	10	6000
2.165	0.492	236.220	3.024	4.506	55	13	6000
2.165	0.591	157.480	3.415	5.089	55	15	4000
2.244	0.197	157.480	1.480	2.205	57	5	4000
2.323	0.689	157.480	4.133	6.160	59	18	4000
2.362	0.197	157.480	1.565	2.333	60	5	4000
2.362	0.276	157.480	2.112	3.147	60	7	4000
2.362	0.315	157.480	2.368	3.529	60	8	4000
2.362	0.394	236.220	2.846	4.241	60	10	6000
2.362	0.591	236.220	3.842	5.726	60	15	6000
2.362	0.787	236.220	4.553	6.786	60	20	6000
2.559	0.197	157.480	1.707	2.545	65	5	4000
2.559	0.394	196.850	3.130	4.665	65	10	5000

Imperial Unit			Unit Weight		International Unit		
OD/in	Wall/in	Length/in	Lbs/FT	Kg/m	OD/mm	Wall/mm	Length/mm
2.559	0.591	157.480	4.269	6.362	65	15	4000
2.559	0.787	236.220	5.122	7.634	65	20	6000
2.756	0.197	157.480	1.850	2.757	70	5	4000
2.756	0.295	118.110	2.668	3.976	70	8	3000
2.756	0.394	236.220	3.415	5.089	70	10	6000
2.756	0.591	236.220	4.695	6.998	70	15	6000
2.756	0.787	157.480	5.691	8.482	70	20	4000
2.835	0.236	157.480	2.254	3.359	72	6	4000
2.953	0.197	157.480	1.992	2.969	75	5	4000
2.953	0.394	236.220	3.699	5.513	75	10	6000
2.953	0.591	236.220	5.122	7.634	75	15	6000
2.992	0.197	157.480	2.020	3.011	76	5	4000
2.992	0.236	157.480	2.390	3.563	76	6	4000
3.150	0.197	157.480	2.134	3.181	80	5	4000
3.150	0.236	157.480	2.527	3.766	80	6	4000
3.150	0.394	236.220	3.984	5.938	80	10	6000
3.150	0.591	157.480	5.549	8.270	80	15	4000
3.150	0.787	157.480	6.830	10.179	80	20	4000
3.150	0.984	118.110	7.826	11.663	80	25	3000
3.346	0.256	157.480	2.904	4.328	85	7	4000
3.346	0.394	236.220	4.269	6.362	85	10	6000
3.346	0.591	157.480	5.976	8.906	85	15	4000
3.346	0.787	157.480	7.399	11.027	85	20	4000
3.346	0.984	118.110	8.537	12.723	85	25	3000
3.543	0.236	236.220	2.868	4.275	90	6	6000
3.543	0.394	236.220	4.553	6.786	90	10	6000
3.543	0.591	157.480	6.403	9.543	90	15	4000

Imperial Unit			Unit Weight		International Unit		
OD/in	Wall/in	Length/in	Lbs/FT	Kg/m	OD/mm	Wall/mm	Length/mm
3.543	0.787	118.110	7.968	11.875	90	20	3000
3.543	0.984	118.110	9.249	13.784	90	25	3000
3.740	0.394	236.220	4.838	7.210	95	10	6000
3.740	0.591	157.480	6.830	10.179	95	15	4000
3.937	0.394	236.220	5.122	7.634	100	10	6000
3.937	0.591	157.480	7.257	10.815	100	15	4000
3.937	0.787	118.110	9.106	13.572	100	20	3000
3.937	0.984	236.220	10.671	15.904	100	25	6000
3.937	1.181	236.220	11.952	17.813	100	30	6000
4.134	0.394	236.220	5.407	8.058	105	10	6000
4.134	0.492	236.220	6.581	9.808	105	13	6000
4.134	0.591	157.480	7.683	11.451	105	15	4000
4.331	0.394	157.480	5.691	8.482	110	10	4000
4.331	0.591	157.480	8.110	12.087	110	15	4000
4.331	0.787	98.425	10.245	15.268	110	20	2500
4.331	0.984	236.220	12.094	18.025	110	25	6000
4.331	1.181	236.220	13.659	20.358	110	30	6000
4.528	0.394	157.480	5.976	8.906	115	10	4000
4.528	0.591	118.110	8.537	12.723	115	15	3000
4.724	0.394	157.480	6.261	9.331	120	10	4000
4.724	0.591	118.110	8.964	13.360	120	15	3000
4.724	0.787	236.220	11.383	16.965	120	20	6000
4.724	0.984	236.220	13.517	20.145	120	25	6000
4.724	1.181	236.220	15.367	22.902	120	30	6000
4.724	1.575	236.220	18.213	27.143	120	40	6000
4.803	1.063	62.992	14.599	21.757	122	27	1600
4.921	0.394	157.480	6.545	9.755	125	10	4000

Imperial Unit			Unit Weight		International Unit		
OD/in	Wall/in	Length/in	Lbs/FT	Kg/m	OD/mm	Wall/mm	Length/mm
4.921	0.591	118.110	9.391	13.996	125	15	3000
4.921	0.787	236.220	11.952	17.813	125	20	6000
4.921	0.984	196.850	14.229	21.206	125	25	5000
5.118	0.394	157.480	6.830	10.179	130	10	4000
5.118	0.591	118.110	9.818	14.632	130	15	3000
5.118	0.787	236.220	12.521	18.661	130	20	6000
5.118	0.984	236.220	14.940	22.266	130	25	6000
5.118	1.181	236.220	17.074	25.447	130	30	6000
5.118	1.575	236.220	20.489	30.536	130	40	6000
5.315	0.689	236.220	11.703	17.442	135	18	6000
5.394	1.575	236.220	22.083	32.911	137	40	6000
5.512	0.394	157.480	7.399	11.027	140	10	4000
5.512	0.591	236.220	10.671	15.904	140	15	6000
5.512	0.787	236.220	13.659	20.358	140	20	6000
5.512	1.181	236.220	18.782	27.992	140	30	6000
5.512	1.575	236.220	22.766	33.929	140	40	6000
5.591	1.339	48.425	20.899	31.147	142	34	1230
5.709	0.591	236.220	11.098	16.540	145	15	6000
5.709	0.886	236.220	15.687	23.379	145	23	6000
5.906	0.394	118.110	7.968	11.875	150	10	3000
5.906	0.591	236.220	11.525	17.177	150	15	6000
5.906	0.787	236.220	14.798	22.054	150	20	6000
5.906	0.984	236.220	17.786	26.507	150	25	6000
5.906	1.181	236.220	20.489	30.536	150	30	6000
5.906	1.575	236.220	25.042	37.322	150	40	6000
5.906	1.969	236.220	28.457	42.412	150	50	6000
6.102	0.492	236.220	10.138	15.109	155	13	6000

Imperial Unit			Unit Weight		International Unit		
OD/in	Wall/in	Length/in	Lbs/FT	Kg/m	OD/mm	Wall/mm	Length/mm
6.102	0.689	236.220	13.695	20.411	155	18	6000
6.299	0.394	118.110	8.537	12.723	160	10	3000
6.299	0.591	236.220	12.379	18.449	160	15	6000
6.299	0.787	236.220	15.936	23.750	160	20	6000
6.299	1.181	236.220	22.197	33.081	160	30	6000
6.299	1.575	236.220	27.319	40.715	160	40	6000
6.299	1.969	157.480	31.303	46.653	160	50	4000
6.614	0.866	236.220	18.281	27.245	168	22	6000
6.693	0.394	118.110	9.106	13.572	170	10	3000
6.693	0.591	236.220	13.233	19.721	170	15	6000
6.693	0.787	236.220	17.074	25.447	170	20	6000
6.693	1.181	236.220	23.904	35.626	170	30	6000
6.693	1.575	157.480	29.596	44.108	170	40	4000
6.693	1.969	157.480	34.149	50.894	170	50	4000
6.890	0.591	236.220	13.659	20.358	175	15	6000
6.890	0.787	236.220	17.643	26.295	175	20	6000
7.087	0.394	236.220	9.675	14.420	180	10	6000
7.087	0.591	236.220	14.086	20.994	180	15	6000
7.087	0.787	236.220	18.213	27.143	180	20	6000
7.087	1.181	236.220	25.612	38.170	180	30	6000
7.087	1.969	157.480	36.994	55.135	180	50	4000
7.087	1.575	157.480	31.872	47.501	180	40	4000
7.087	1.969	157.480	36.994	55.135	180	50	4000
7.283	0.394	236.220	9.960	14.844	185	10	6000
7.283	0.591	236.220	14.513	21.630	185	15	6000
7.480	0.394	236.220	10.245	15.268	190	10	6000
7.480	0.433	236.220	11.206	16.702	190	11	6000

Imperial Unit			Unit Weight		International Unit		
OD/in	Wall/in	Length/in	Lbs/FT	Kg/m	OD/mm	Wall/mm	Length/mm
7.480	0.591	236.220	14.940	22.266	190	15	6000
7.480	0.787	236.220	19.351	28.840	190	20	6000
7.480	0.984	236.220	23.477	34.989	190	25	6000
7.480	1.181	157.480	27.319	40.715	190	30	4000
7.480	1.575	157.480	34.149	50.894	190	40	4000
7.480	1.969	157.480	39.840	59.376	190	50	4000
7.559	0.472	236.220	12.294	18.322	192	12	6000
7.677	0.787	236.220	19.920	29.688	195	20	6000
7.874	0.394	236.220	10.814	16.116	200	10	6000
7.874	0.591	236.220	15.794	23.538	200	15	6000
7.874	0.787	236.220	20.489	30.536	200	20	6000
7.874	0.984	236.220	24.900	37.110	200	25	6000
7.874	1.181	236.220	29.026	43.260	200	30	6000
7.874	1.575	236.220	36.425	54.287	200	40	6000
7.874	1.575	157.480	36.425	54.287	200	40	4000
7.874	1.969	157.480	42.686	63.617	200	50	4000
7.874	2.362	118.110	47.808	71.251	200	60	3000
8.000	1.000	236.220	25.703	38.307	203	25	6000
8.268	0.197	236.220	5.834	8.694	210	5	6000
8.268	0.787	236.220	21.628	32.233	210	20	6000
8.268	0.984	236.220	26.323	39.231	210	25	6000
8.268	1.181	157.480	30.734	45.804	210	30	4000
8.268	1.575	157.480	38.702	57.680	210	40	4000
8.268	1.969	157.480	45.532	67.858	210	50	4000
8.622	0.500	157.480	14.912	22.224	219	13	4000
8.661	0.197	236.220	6.118	9.118	220	5	6000
8.661	0.394	236.220	11.952	17.813	220	10	6000

Imperial Unit			Unit Weight		International Unit		
OD/in	Wall/in	Length/in	Lbs/FT	Kg/m	OD/mm	Wall/mm	Length/mm
8.661	0.591	236.220	17.501	26.083	220	15	6000
8.661	0.787	236.220	22.766	33.929	220	20	6000
8.661	1.181	236.220	32.441	48.349	220	30	6000
8.661	1.575	157.480	40.978	61.073	220	40	4000
8.661	1.969	157.480	48.377	72.100	220	50	4000
8.661	2.362	157.480	54.638	81.430	220	60	4000
9.055	0.394	236.220	12.521	18.661	230	10	6000
9.055	0.591	236.220	18.355	27.355	230	15	6000
9.055	0.787	236.220	23.904	35.626	230	20	6000
9.055	1.437	236.220	40.197	59.908	230	37	6000
9.055	1.181	157.480	34.149	50.894	230	30	4000
9.055	1.575	157.480	43.255	64.465	230	40	4000
9.055	1.969	118.110	51.223	76.341	230	50	3000
9.055	2.362	118.110	58.053	86.519	230	60	3000
9.449	0.197	236.220	6.687	9.967	240	5	6000
9.449	0.394	236.220	13.090	19.509	240	10	6000
9.449	0.630	236.220	20.398	30.401	240	16	6000
9.449	0.787	157.480	25.042	37.322	240	20	4000
9.449	1.181	157.480	35.856	53.438	240	30	4000
9.449	1.575	118.110	45.532	67.858	240	40	3000
9.449	1.969	157.480	54.069	80.582	240	50	4000
9.488	0.748	236.220	24.007	35.778	241	19	6000
9.843	0.197	236.220	6.972	10.391	250	5	6000
9.843	0.394	236.220	13.659	20.358	250	10	6000
9.843	0.787	236.220	26.181	39.019	250	20	6000
9.843	1.181	236.220	37.564	55.983	250	30	6000
9.843	0.984	118.110	32.014	47.713	250	25	3000

Imperial Unit			Unit Weight		International Unit		
OD/in	Wall/in	Length/in	Lbs/FT	Kg/m	OD/mm	Wall/mm	Length/mm
9.843	1.575	98.425	47.808	71.251	250	40	2500
9.843	1.969	157.480	56.914	84.823	250	50	4000
10.000	0.622	236.220	21.420	31.924	254	16	6000
10.000	1.004	236.220	33.163	49.424	254	26	6000
10.236	0.315	236.220	11.474	17.100	260	8	6000
10.236	0.787	236.220	27.319	40.715	260	20	6000
10.236	1.181	236.220	39.271	58.528	260	30	6000
10.236	0.787	157.480	27.319	40.715	260	20	4000
10.236	1.575	98.425	50.085	74.644	260	40	2500
10.236	1.969	78.740	59.760	89.064	260	50	2000
10.551	0.315	236.220	11.838	17.643	268	8	6000
10.630	0.394	236.220	14.798	22.054	270	10	6000
10.630	0.787	137.795	28.457	42.412	270	20	3500
10.630	1.181	78.740	40.978	61.073	270	30	2000
10.630	1.575	78.740	52.361	78.037	270	40	2000
10.630	1.969	78.740	62.606	93.305	270	50	2000
11.024	0.394	157.480	15.367	22.902	280	10	4000
11.024	1.181	236.220	42.686	63.617	280	30	6000
11.024	0.787	118.110	29.596	44.108	280	20	3000
11.024	1.575	39.370	54.638	81.430	280	40	1000
11.024	1.969	39.370	65.452	97.546	280	50	1000
11.260	0.315	236.220	12.658	18.865	286	8	6000
11.417	1.181	39.370	44.393	66.162	290	30	1000
11.417	1.575	39.370	56.914	84.823	290	40	1000
11.417	1.969	39.370	68.297	101.788	290	50	1000
11.417	2.362	39.370	78.542	117.056	290	60	1000
11.732	0.846	236.220	33.834	50.425	298	22	6000

Imperial Unit			Unit Weight		International Unit		
OD/in	Wall/in	Length/in	Lbs/FT	Kg/m	OD/mm	Wall/mm	Length/mm
11.811	0.394	236.220	16.505	24.599	300	10	6000
11.811	0.591	236.220	24.331	36.262	300	15	6000
11.811	1.181	236.220	46.101	68.707	300	30	6000
11.811	3.937	39.370	113.829	169.646	300	100	1000
11.811	1.575	39.370	59.191	88.216	300	40	1000
11.811	1.969	39.370	71.143	106.029	300	50	1000
11.811	2.362	39.370	81.957	122.145	300	60	1000
12.205	1.181	39.370	47.808	71.251	310	30	1000
12.205	1.575	39.370	61.468	91.609	310	40	1000
12.205	1.969	39.370	73.989	110.270	310	50	1000
12.598	0.394	236.220	17.643	26.295	320	10	6000
12.598	0.984	236.220	41.974	62.557	320	25	6000
12.598	1.969	236.220	76.835	114.511	320	50	6000
12.598	1.181	20.079	49.516	73.796	320	30	510
12.598	1.575	39.370	63.744	95.002	320	40	1000
12.598	1.969	39.370	76.835	114.511	320	50	1000
12.992	1.181	39.370	51.223	76.341	330	30	1000
12.992	1.575	20.079	66.021	98.395	330	40	510
12.992	1.969	39.370	79.680	118.752	330	50	1000
13.386	0.394	236.220	18.782	27.992	340	10	6000
13.386	1.181	39.370	52.930	78.885	340	30	1000
13.386	1.575	39.370	68.297	101.788	340	40	1000
13.386	1.969	39.370	82.526	122.993	340	50	1000
13.386	2.362	39.370	95.616	142.503	340	60	1000
13.661	0.591	236.220	28.343	42.242	347	15	6000
13.780	0.472	236.220	23.085	34.404	350	12	6000
13.780	1.969	118.110	85.372	127.235	350	50	3000

Imperial Unit			Unit Weight		International Unit		
OD/in	Wall/in	Length/in	Lbs/FT	Kg/m	OD/mm	Wall/mm	Length/mm
13.780	1.181	39.370	54.638	81.430	350	30	1000
13.780	1.575	39.370	70.574	105.181	350	40	1000
13.780	1.969	39.370	85.372	127.235	350	50	1000
13.780	2.362	39.370	99.031	147.592	350	60	1000
14.016	0.413	236.220	20.647	30.772	356	11	6000
14.173	1.181	20.079	56.345	83.975	360	30	510
14.173	1.575	39.370	72.851	108.573	360	40	1000
14.173	1.969	39.370	88.217	131.476	360	50	1000
14.173	2.362	39.370	102.446	152.681	360	60	1000
14.567	0.591	236.220	30.307	45.168	370	15	6000
14.567	1.181	39.370	58.053	86.519	370	30	1000
14.567	1.575	39.370	75.127	111.966	370	40	1000
14.567	1.969	39.370	91.063	135.717	370	50	1000
14.961	1.575	236.220	77.404	115.359	380	40	6000
14.961	1.181	39.370	59.760	89.064	380	30	1000
14.961	1.575	39.370	77.404	115.359	380	40	1000
14.961	1.969	39.370	93.909	139.958	380	50	1000
15.354	1.181	20.079	61.468	91.609	390	30	510
15.354	1.575	39.370	79.680	118.752	390	40	1000
15.354	1.969	39.370	96.755	144.199	390	50	1000
15.354	2.362	39.370	112.691	167.950	390	60	1000
15.748	0.394	236.220	22.197	33.081	400	10	6000
15.748	3.937	39.370	170.743	254.469	400	100	1000
15.748	1.181	20.079	63.175	94.154	400	30	510
15.748	1.575	39.370	81.957	122.145	400	40	1000
15.748	1.969	39.370	99.600	148.440	400	50	1000
15.827	0.433	236.220	24.479	36.482	402	11	6000

Imperial Unit			Unit Weight		International Unit		
OD/in	Wall/in	Length/in	Lbs/FT	Kg/m	OD/mm	Wall/mm	Length/mm
16.142	1.181	39.370	64.883	96.698	410	30	1000
16.142	1.575	39.370	84.233	125.538	410	40	1000
16.142	1.969	39.370	102.446	152.681	410	50	1000
16.535	3.937	39.370	182.126	271.434	420	100	1000
16.535	1.181	39.370	66.590	99.243	420	30	1000
16.535	1.575	39.370	86.510	128.931	420	40	1000
16.535	1.969	39.370	105.292	156.923	420	50	1000
16.929	1.181	20.079	68.297	101.788	430	30	510
16.929	1.575	39.370	88.787	132.324	430	40	1000
16.929	1.969	39.370	108.138	161.164	430	50	1000
17.323	4.331	41.339	206.600	307.907	440	110	1050
17.323	4.626	39.370	215.670	321.426	440	118	1000
17.323	1.181	39.370	70.005	104.332	440	30	1000
17.323	1.575	39.370	91.063	135.717	440	40	1000
17.323	1.969	39.370	110.983	165.405	440	50	1000
17.717	1.181	39.370	71.712	106.877	450	30	1000
17.717	1.575	39.370	93.340	139.110	450	40	1000
17.717	1.969	39.370	113.829	169.646	450	50	1000
17.717	2.362	39.370	133.180	198.486	450	60	1000
17.795	0.354	236.220	22.692	33.819	452	9	6000
18.110	1.181	39.370	73.420	109.422	460	30	1000
18.110	1.575	39.370	95.616	142.503	460	40	1000
18.110	1.969	39.370	116.675	173.887	460	50	1000
18.504	1.181	39.370	75.127	111.966	470	30	1000
18.504	1.575	39.370	97.893	145.896	470	40	1000
18.504	1.969	39.370	119.520	178.128	470	50	1000
18.898	1.181	39.370	76.835	114.511	480	30	1000

Imperial Unit			Unit Weight		International Unit		
OD/in	Wall/in	Length/in	Lbs/FT	Kg/m	OD/mm	Wall/mm	Length/mm
18.898	1.575	39.370	100.169	149.288	480	40	1000
18.898	1.969	39.370	122.366	182.369	480	50	1000
19.291	1.181	39.370	78.542	117.056	490	30	1000
19.291	1.575	20.079	102.446	152.681	490	40	510
19.291	1.969	39.370	125.212	186.611	490	50	1000
19.685	3.937	39.370	227.658	339.292	500	100	1000
19.685	1.181	39.370	80.249	119.600	500	30	1000
19.685	1.575	39.370	104.723	156.074	500	40	1000
19.685	1.969	39.370	128.058	190.852	500	50	1000
20.079	1.181	39.370	81.957	122.145	510	30	1000
20.079	1.575	39.370	106.999	159.467	510	40	1000
20.079	1.969	39.370	130.903	195.093	510	50	1000
20.472	1.181	39.370	83.664	124.690	520	30	1000
20.472	1.575	39.370	109.276	162.860	520	40	1000
20.472	1.969	39.370	133.749	199.334	520	50	1000
20.866	1.181	39.370	85.372	127.235	530	30	1000
20.866	1.575	39.370	111.552	166.253	530	40	1000
20.866	1.969	39.370	136.595	203.575	530	50	1000
21.260	1.181	39.370	87.079	129.779	540	30	1000
21.260	1.575	236.220	113.829	169.646	540	40	6000
21.260	1.969	236.220	139.440	207.816	540	50	6000
21.654	1.181	196.850	88.787	132.324	550	30	5000
21.654	1.575	20.079	116.106	173.039	550	40	510
21.654	1.969	236.220	142.286	212.058	550	50	6000
22.047	1.181	20.079	90.494	134.869	560	30	510
22.047	1.575	20.079	118.382	176.432	560	40	510
22.047	1.969	20.079	145.132	216.299	560	50	510

Imperial Unit			Unit Weight		International Unit		
OD/in	Wall/in	Length/in	Lbs/FT	Kg/m	OD/mm	Wall/mm	Length/mm
22.441	1.181	20.079	92.201	137.413	570	30	510
22.441	1.575	20.079	120.659	179.825	570	40	510
22.441	1.969	20.079	147.978	220.540	570	50	510
22.835	1.181	20.079	93.909	139.958	580	30	510
22.835	1.575	236.220	122.935	183.218	580	40	6000
22.835	1.969	20.079	150.823	224.781	580	50	510
23.228	1.181	236.220	95.616	142.503	590	30	6000
23.228	1.575	236.220	125.212	186.611	590	40	6000
23.228	1.969	236.220	153.669	229.022	590	50	6000
23.622	1.181	20.079	97.324	145.047	600	30	510
23.622	1.575	20.079	127.488	190.004	600	40	510
23.622	1.969	236.220	156.515	233.263	600	50	6000

- Standard aluminum pipe lengths are 2.5m, 3m, 4m, and 6m, with custom lengths up to 15m available.
- We offer cutting, punching, bending, and wall expansion services for all pipes.
- All stock products are available for retail, and orders will be processed and shipped within one week.
- As a one-stop aluminum supplier, we offer discounts for bulk purchases.
- All stock weights are density-based estimates and may differ from actual weights.

6061 T6 Seamless aluminum pipe tube

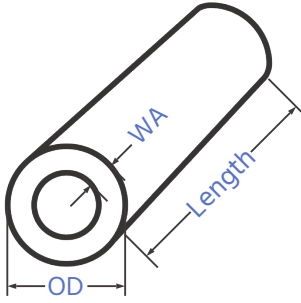

Specs: ASTM B210,ASTM B241,AMS-WWT-700/6,MIL-T-7081,MIL-T-8506

Imperial Unit		Unit Weight		International Unit	
OD/in	Wall/in	Lbs/FT	Kg/m	OD/mm	Wall/mm
0.551	0.098	0.164	0.244	14	3
0.591	0.118	0.205	0.305	15	3
0.610	0.108	0.200	0.297	16	3
0.669	0.138	0.269	0.401	17	4
0.709	0.157	0.319	0.475	18	4
0.787	0.197	0.427	0.636	20	5
0.787	0.157	0.364	0.543	20	4
0.787	0.079	0.205	0.305	20	2
0.799	0.183	0.414	0.617	20	5
0.827	0.295	0.576	0.859	21	8
0.827	0.236	0.512	0.763	21	6
0.827	0.197	0.455	0.679	21	5
0.866	0.413	0.687	1.024	22	11
0.866	0.138	0.369	0.549	22	4
0.866	0.118	0.324	0.483	22	3
0.906	0.236	0.581	0.865	23	6
0.906	0.138	0.388	0.579	23	4
0.906	0.118	0.341	0.509	23	3
0.945	0.232	0.608	0.906	24	6
0.984	0.335	0.798	1.190	25	9
0.984	0.276	0.717	1.069	25	7

Imperial Unit		Unit Weight		International Unit	
OD/in	Wall/in	Lbs/FT	Kg/m	OD/mm	Wall/mm
0.984	0.256	0.684	1.020	25	7
0.984	0.118	0.376	0.560	25	3
1.024	0.236	0.683	1.018	26	6
1.024	0.138	0.448	0.668	26	4
1.024	0.118	0.393	0.585	26	3
1.063	0.354	0.922	1.374	27	9
1.063	0.256	0.758	1.130	27	7
1.102	0.266	0.816	1.217	28	7
1.102	0.157	0.546	0.814	28	4
1.102	0.118	0.427	0.636	28	3
1.142	0.197	0.683	1.018	29	5
1.181	0.394	1.138	1.696	30	10
1.181	0.295	0.960	1.431	30	8
1.181	0.236	0.820	1.221	30	6
1.181	0.157	0.592	0.882	30	4
1.220	0.256	0.906	1.351	31	7
1.220	0.217	0.798	1.190	31	6
1.260	0.394	1.252	1.866	32	10
1.260	0.374	1.217	1.813	32	10
1.260	0.335	1.137	1.694	32	9
1.260	0.295	1.046	1.559	32	8
1.260	0.197	0.768	1.145	32	5
1.260	0.138	0.568	0.846	32	4
1.299	0.354	1.229	1.832	33	9
1.299	0.344	1.208	1.800	33	9
1.299	0.335	1.185	1.766	33	9
1.299	0.276	1.036	1.544	33	7

Imperial Unit		Unit Weight		International Unit	
OD/in	Wall/in	Lbs/FT	Kg/m	OD/mm	Wall/mm
1.299	0.256	0.980	1.461	33	7
1.299	0.177	0.730	1.088	33	5
1.378	0.413	1.464	2.182	35	11
1.378	0.394	1.423	2.121	35	10
1.378	0.138	0.627	0.935	35	4
1.378	0.098	0.462	0.689	35	3
1.417	0.413	1.524	2.271	36	11
1.417	0.335	1.330	1.983	36	9
1.496	0.394	1.594	2.375	38	10
1.496	0.157	0.774	1.154	38	4
1.496	0.118	0.598	0.891	38	3
1.535	0.236	1.127	1.679	39	6
1.575	0.453	1.865	2.780	40	12
1.575	0.394	1.707	2.545	40	10
1.575	0.295	1.387	2.068	40	8
1.575	0.197	0.996	1.484	40	5
1.575	0.157	0.820	1.221	40	4
1.575	0.118	0.632	0.942	40	3
1.614	0.413	1.823	2.716	41	11
1.654	0.472	2.049	3.054	42	12
1.654	0.354	1.690	2.519	42	9
1.654	0.276	1.394	2.078	42	7
1.654	0.138	0.767	1.143	42	4
1.693	0.482	2.144	3.195	43	12
1.732	0.157	0.911	1.357	44	4
1.772	0.610	2.602	3.879	45	16
1.772	0.551	2.470	3.681	45	14

Imperial Unit		Unit Weight		International Unit	
OD/in	Wall/in	Lbs/FT	Kg/m	OD/mm	Wall/mm
1.772	0.394	1.992	2.969	45	10
1.772	0.295	1.601	2.386	45	8
1.811	0.236	1.366	2.036	46	6
1.811	0.197	1.167	1.739	46	5
1.890	0.197	1.224	1.824	48	5
1.969	0.591	2.988	4.453	50	15
1.969	0.394	2.277	3.393	50	10
1.969	0.197	1.281	1.909	50	5
2.165	0.591	3.415	5.089	55	15
2.165	0.394	2.561	3.817	55	10
2.362	0.787	4.553	6.786	60	20
2.362	0.591	3.842	5.726	60	15
2.362	0.394	2.846	4.241	60	10
2.559	0.591	4.269	6.362	65	15
2.559	0.394	3.130	4.665	65	10
2.756	0.591	4.695	6.998	70	15
2.756	0.394	3.415	5.089	70	10
2.756	0.197	1.850	2.757	70	5
3.150	0.787	6.830	10.179	80	20
3.150	0.591	5.549	8.270	80	15
3.150	0.394	3.984	5.938	80	10
3.150	0.197	2.134	3.181	80	5
3.346	0.394	4.269	6.362	85	10
3.543	0.787	7.968	11.875	90	20
3.543	0.591	6.403	9.543	90	15
3.543	0.394	4.553	6.786	90	10
3.543	0.197	2.419	3.605	90	5

Imperial Unit		Unit Weight		International Unit	
OD/in	Wall/in	Lbs/FT	Kg/m	OD/mm	Wall/mm
3.937	1.181	11.952	17.813	100	30
3.937	0.984	10.671	15.904	100	25
3.937	0.787	9.106	13.572	100	20
3.937	0.394	5.122	7.634	100	10
3.937	0.197	2.703	4.029	100	5
4.331	1.181	13.659	20.358	110	30
4.331	0.984	12.094	18.025	110	25
4.331	0.787	10.245	15.268	110	20
4.331	0.591	8.110	12.087	110	15
4.331	0.394	5.691	8.482	110	10
4.331	0.197	2.988	4.453	110	5
4.567	1.594	17.403	25.937	116	41
4.724	1.575	18.213	27.143	120	40
4.724	1.181	15.367	22.902	120	30
4.724	0.984	13.517	20.145	120	25
4.724	0.787	11.383	16.965	120	20
4.724	0.591	8.964	13.360	120	15
4.724	0.394	6.261	9.331	120	10
5.118	1.575	20.489	30.536	130	40
5.118	1.181	17.074	25.447	130	30
5.118	0.984	14.940	22.266	130	25
5.118	0.787	12.521	18.661	130	20
5.118	0.591	9.818	14.632	130	15
5.118	0.394	6.830	10.179	130	10
5.118	0.197	3.557	5.301	130	5
5.512	1.969	25.612	38.170	140	50
5.512	1.575	22.766	33.929	140	40

Imperial Unit		Unit Weight		International Unit	
OD/in	Wall/in	Lbs/FT	Kg/m	OD/mm	Wall/mm
5.512	1.378	20.916	31.172	140	35
5.512	1.181	18.782	27.992	140	30
5.512	0.984	16.363	24.387	140	25
5.512	0.787	13.659	20.358	140	20
5.512	0.591	10.671	15.904	140	15
5.512	0.394	7.399	11.027	140	10
5.512	0.197	3.842	5.726	140	5
5.709	0.492	9.426	14.049	145	13
5.906	1.969	28.457	42.412	150	50
5.906	1.575	25.042	37.322	150	40
5.906	1.378	22.908	34.141	150	35
5.906	1.181	20.489	30.536	150	30
5.906	0.984	17.786	26.507	150	25
5.906	0.787	14.798	22.054	150	20
5.906	0.591	11.525	17.177	150	15
5.906	0.394	7.968	11.875	150	10
5.906	0.197	4.126	6.150	150	5
6.102	0.984	18.497	27.567	155	25
6.102	0.787	15.367	22.902	155	20
6.299	1.969	31.303	46.653	160	50
6.299	1.575	27.319	40.715	160	40
6.299	1.378	24.900	37.110	160	35
6.299	1.181	22.197	33.081	160	30
6.299	1.083	20.738	30.907	160	28
6.299	0.984	19.209	28.628	160	25
6.299	0.787	15.936	23.750	160	20
6.299	0.591	12.379	18.449	160	15

Imperial Unit		Unit Weight		International Unit	
OD/in	Wall/in	Lbs/FT	Kg/m	OD/mm	Wall/mm
6.299	0.394	8.537	12.723	160	10
6.299	0.197	4.411	6.574	160	5
6.417	1.378	25.498	38.001	163	35
6.496	0.984	19.920	29.688	165	25
6.693	1.969	34.149	50.894	170	50
6.693	1.575	29.596	44.108	170	40
6.693	1.378	26.892	40.079	170	35
6.693	1.181	23.904	35.626	170	30
6.693	0.984	20.632	30.748	170	25
6.693	0.787	17.074	25.447	170	20
6.693	0.591	13.233	19.721	170	15
6.693	0.394	9.106	13.572	170	10
6.693	0.197	4.695	6.998	170	5
6.890	0.591	13.659	20.358	175	15
7.087	1.969	36.994	55.135	180	50
7.087	1.575	31.872	47.501	180	40
7.087	1.181	25.612	38.170	180	30
7.087	0.984	22.054	32.869	180	25
7.087	0.787	18.213	27.143	180	20
7.087	0.197	4.980	7.422	180	5
7.087	0.591	14.086	20.994	180	15
7.087	0.394	9.675	14.420	180	10
7.283	0.984	22.766	33.929	185	25
7.283	0.689	16.683	24.864	185	18
7.283	0.591	14.513	21.630	185	15
7.283	0.394	9.960	14.844	185	10
7.480	1.969	39.840	59.376	190	50

Imperial Unit		Unit Weight		International Unit	
OD/in	Wall/in	Lbs/FT	Kg/m	OD/mm	Wall/mm
7.480	1.575	34.149	50.894	190	40
7.480	1.181	27.319	40.715	190	30
7.480	0.984	23.477	34.989	190	25
7.480	0.787	19.351	28.840	190	20
7.480	0.591	14.940	22.266	190	15
7.480	0.512	13.096	19.518	190	13
7.480	0.197	5.265	7.846	190	5
7.874	2.362	47.808	71.251	200	60
7.874	1.969	42.686	63.617	200	50
7.874	1.772	39.698	59.164	200	45
7.874	1.575	36.425	54.287	200	40
7.874	1.378	32.868	48.985	200	35
7.874	1.181	29.026	43.260	200	30
7.874	0.984	24.900	37.110	200	25
7.874	0.591	15.794	23.538	200	15
7.874	0.394	10.814	16.116	200	10
7.874	0.197	5.549	8.270	200	5
8.268	1.772	42.259	62.981	210	45
8.268	1.575	38.702	57.680	210	40
8.268	1.378	34.860	51.954	210	35
8.268	1.181	30.734	45.804	210	30
8.268	0.984	26.323	39.231	210	25
8.268	0.787	21.628	32.233	210	20
8.268	0.591	16.647	24.811	210	15
8.268	0.394	11.383	16.965	210	10
8.268	0.197	5.834	8.694	210	5
8.661	2.362	54.638	81.430	220	60

Imperial Unit		Unit Weight		International Unit	
OD/in	Wall/in	Lbs/FT	Kg/m	OD/mm	Wall/mm
8.661	1.969	48.377	72.100	220	50
8.661	1.575	40.978	61.073	220	40
8.661	1.378	36.852	54.923	220	35
8.661	1.181	32.441	48.349	220	30
8.661	0.984	27.746	41.351	220	25
8.661	0.787	22.766	33.929	220	20
8.661	0.591	17.501	26.083	220	15
8.661	0.394	11.952	17.813	220	10
9.055	1.575	43.255	64.465	230	40
9.055	1.437	40.197	59.908	230	37
9.055	1.181	34.149	50.894	230	30
9.055	0.984	29.169	43.472	230	25
9.055	0.787	23.904	35.626	230	20
9.055	0.591	18.355	27.355	230	15
9.055	0.394	12.521	18.661	230	10
9.449	2.362	61.468	91.609	240	60
9.449	1.969	54.069	80.582	240	50
9.449	1.772	49.942	74.432	240	45
9.449	1.575	45.532	67.858	240	40
9.449	1.378	40.836	60.861	240	35
9.449	1.181	35.856	53.438	240	30
9.449	0.984	30.592	45.592	240	25
9.449	0.787	25.042	37.322	240	20
9.449	0.591	19.209	28.628	240	15
9.449	0.394	13.090	19.509	240	10
9.843	2.362	64.883	96.698	250	60
9.843	1.969	56.914	84.823	250	50

Imperial Unit		Unit Weight		International Unit	
OD/in	Wall/in	Lbs/FT	Kg/m	OD/mm	Wall/mm
9.843	1.575	47.808	71.251	250	40
9.843	1.378	42.828	63.829	250	35
9.843	1.181	37.564	55.983	250	30
9.843	0.984	32.014	47.713	250	25
9.843	0.787	26.181	39.019	250	20
9.843	0.591	20.062	29.900	250	15
9.843	0.394	13.659	20.358	250	10
10.236	2.165	64.171	95.638	260	55
10.236	1.969	59.760	89.064	260	50
10.236	1.575	50.085	74.644	260	40
10.236	1.378	44.820	66.798	260	35
10.236	1.181	39.271	58.528	260	30
10.236	0.787	27.319	40.715	260	20
10.236	0.591	20.916	31.172	260	15
10.236	0.394	14.229	21.206	260	10
10.630	1.969	62.606	93.305	270	50
10.630	1.575	52.361	78.037	270	40
10.630	1.378	46.812	69.767	270	35
10.630	1.181	40.978	61.073	270	30
10.630	0.787	28.457	42.412	270	20
10.630	0.591	21.770	32.445	270	15
10.630	0.394	14.798	22.054	270	10
11.024	2.362	75.127	111.966	280	60
11.024	1.969	65.452	97.546	280	50
11.024	1.772	60.187	89.700	280	45
11.024	1.575	54.638	81.430	280	40
11.024	1.181	42.686	63.617	280	30

Imperial Unit		Unit Weight		International Unit	
OD/in	Wall/in	Lbs/FT	Kg/m	OD/mm	Wall/mm
11.024	0.787	29.596	44.108	280	20
11.024	0.591	22.624	33.717	280	15
11.024	0.394	15.367	22.902	280	10
11.417	2.362	78.542	117.056	290	60
11.417	1.969	68.297	101.788	290	50
11.417	1.575	56.914	84.823	290	40
11.417	1.181	44.393	66.162	290	30
11.417	0.787	30.734	45.804	290	20
11.417	0.591	23.477	34.989	290	15
11.417	0.394	15.936	23.750	290	10
11.811	2.362	81.957	122.145	300	60
11.811	1.969	71.143	106.029	300	50
11.811	1.575	59.191	88.216	300	40
11.811	1.181	46.101	68.707	300	30
11.811	0.984	39.129	58.316	300	25
11.811	0.787	31.872	47.501	300	20
11.811	0.394	16.505	24.599	300	10
11.929	1.043	41.703	62.152	303	27
12.205	1.969	73.989	110.270	310	50
12.205	1.575	61.468	91.609	310	40
12.205	1.378	54.780	81.642	310	35
12.205	1.181	47.808	71.251	310	30
12.205	0.984	40.552	60.436	310	25
12.205	0.787	33.010	49.197	310	20
12.205	0.591	25.185	37.534	310	15
12.205	0.394	17.074	25.447	310	10
12.598	1.969	76.835	114.511	320	50

Imperial Unit		Unit Weight		International Unit	
OD/in	Wall/in	Lbs/FT	Kg/m	OD/mm	Wall/mm
12.598	1.575	63.744	95.002	320	40
12.598	1.181	49.516	73.796	320	30
12.598	0.984	41.974	62.557	320	25
12.598	0.787	34.149	50.894	320	20
12.598	0.591	26.038	38.807	320	15
12.598	0.394	17.643	26.295	320	10
12.992	1.969	79.680	118.752	330	50
12.992	1.575	66.021	98.395	330	40
12.992	1.181	51.223	76.341	330	30
12.992	0.984	43.397	64.678	330	25
12.992	0.787	35.287	52.590	330	20
12.992	0.591	26.892	40.079	330	15
12.992	0.394	18.213	27.143	330	10
13.386	1.575	68.297	101.788	340	40
13.386	1.378	60.756	90.549	340	35
13.386	1.181	52.930	78.885	340	30
13.386	0.984	44.820	66.798	340	25
13.386	0.787	36.425	54.287	340	20
13.386	0.591	27.746	41.351	340	15
13.780	1.575	70.574	105.181	350	40
13.780	1.181	54.638	81.430	350	30
14.173	0.984	47.666	71.039	360	25
14.567	1.575	75.127	111.966	370	40
14.961	1.575	77.404	115.359	380	40
15.354	1.575	79.680	118.752	390	40
15.748	0.394	22.197	33.081	400	10
15.748	1.575	81.957	122.145	400	40

Imperial Unit		Unit Weight		International Unit	
OD/in	Wall/in	Lbs/FT	Kg/m	OD/mm	Wall/mm
16.535	1.575	86.510	128.931	420	40
16.535	1.969	105.292	156.923	420	50
16.929	1.181	68.297	101.788	430	30
16.929	1.575	88.787	132.324	430	40
16.929	1.969	108.138	161.164	430	50
17.323	4.331	206.600	307.907	440	110
17.323	4.626	215.670	321.426	440	118
17.323	1.181	70.005	104.332	440	30
17.323	1.575	91.063	135.717	440	40
17.323	1.969	110.983	165.405	440	50
17.717	1.181	71.712	106.877	450	30
17.717	1.575	93.340	139.110	450	40
17.717	1.969	113.829	169.646	450	50
17.717	2.362	133.180	198.486	450	60
17.795	0.354	22.692	33.819	452	9
18.110	1.181	73.420	109.422	460	30
18.110	1.575	95.616	142.503	460	40
18.110	1.969	116.675	173.887	460	50
18.504	1.181	75.127	111.966	470	30
18.504	1.575	97.893	145.896	470	40
18.504	1.969	119.520	178.128	470	50
18.898	1.181	76.835	114.511	480	30
18.898	1.575	100.169	149.288	480	40
18.898	1.969	122.366	182.369	480	50
19.291	1.181	78.542	117.056	490	30
19.291	1.575	102.446	152.681	490	40
19.291	1.969	125.212	186.611	490	50

Imperial Unit		Unit Weight		International Unit	
OD/in	Wall/in	Lbs/FT	Kg/m	OD/mm	Wall/mm
19.685	3.937	227.658	339.292	500	100
19.685	1.181	80.249	119.600	500	30
19.685	1.575	104.723	156.074	500	40
19.685	1.969	128.058	190.852	500	50
20.079	1.181	81.957	122.145	510	30
20.079	1.575	106.999	159.467	510	40
20.079	1.969	130.903	195.093	510	50
20.472	1.181	83.664	124.690	520	30
20.472	1.575	109.276	162.860	520	40
20.472	1.969	133.749	199.334	520	50
20.866	1.181	85.372	127.235	530	30
20.866	1.575	111.552	166.253	530	40
20.866	1.969	136.595	203.575	530	50
21.260	1.181	87.079	129.779	540	30
21.260	1.575	113.829	169.646	540	40
21.260	1.969	139.440	207.816	540	50
21.654	1.181	88.787	132.324	550	30
21.654	1.575	116.106	173.039	550	40
21.654	1.969	142.286	212.058	550	50
22.047	1.181	90.494	134.869	560	30
22.047	1.575	118.382	176.432	560	40
22.047	1.969	145.132	216.299	560	50
22.441	1.181	92.201	137.413	570	30
22.441	1.575	120.659	179.825	570	40
22.441	1.969	147.978	220.540	570	50
22.835	1.181	93.909	139.958	580	30
22.835	1.575	122.935	183.218	580	40

Imperial Unit		Unit Weight		International Unit	
OD/in	Wall/in	Lbs/FT	Kg/m	OD/mm	Wall/mm
22.835	1.969	150.823	224.781	580	50
23.228	1.181	95.616	142.503	590	30
23.228	1.575	125.212	186.611	590	40
23.228	1.969	153.669	229.022	590	50
23.622	1.181	97.324	145.047	600	30
23.622	1.575	127.488	190.004	600	40
23.622	1.969	156.515	233.263	600	50

- Standard aluminum pipe lengths are 2.5m, 3m, 4m, and 6m, with custom lengths up to 15m available.
- We offer cutting, punching, bending, and wall expansion services for all pipes.
- All stock products are available for retail, and orders will be processed and shipped within one week.
- As a one-stop aluminum supplier, we offer discounts for bulk purchases.
- All stock weights are density-based estimates and may differ from actual weights.

6061 T6 Seamless forged aluminum pipe

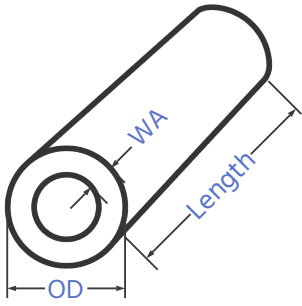

Specs: ASTM B247, MIL-A-22771, AMS 4127

Imperial Unit		Unit Weight		International Unit	
OD/in	Wall/in	Lbs/FT	Kg/m	OD/mm	Wall/mm
11.811	1.575	59.191	88.216	300	40
12.992	2.362	92.201	137.413	330	60
12.992	2.165	86.083	128.295	330	55
12.992	1.969	79.680	118.752	330	50
12.992	1.772	72.993	108.785	330	45
12.992	1.575	66.021	98.395	330	40
13.386	1.181	52.930	78.885	340	30
13.386	1.575	68.297	101.788	340	40
13.386	1.969	82.526	122.993	340	50
13.780	2.362	99.031	147.592	350	60
13.780	1.969	85.372	127.235	350	50
13.780	1.575	70.574	105.181	350	40
13.780	1.181	54.638	81.430	350	30
13.780	1.969	85.372	127.235	350	50
14.173	0.984	47.666	71.039	360	25
14.567	1.378	66.732	99.455	370	35
14.567	1.969	91.063	135.717	370	50
14.567	2.362	105.861	157.771	370	60
14.646	1.831	86.144	128.386	372	47
14.961	2.362	109.276	162.860	380	60
14.961	1.181	59.760	89.064	380	30

Imperial Unit		Unit Weight		International Unit	
OD/in	Wall/in	Lbs/FT	Kg/m	OD/mm	Wall/mm
14.961	1.575	77.404	115.359	380	40
14.961	1.969	93.909	139.958	380	50
14.961	1.870	89.889	133.967	380	48
15.236	3.169	140.427	209.286	387	81
15.354	1.181	61.468	91.609	390	30
15.354	1.575	79.680	118.752	390	40
15.354	1.969	96.755	144.199	390	50
15.748	2.362	116.106	173.039	400	60
15.748	1.969	99.600	148.440	400	50
15.748	1.575	81.957	122.145	400	40
15.748	1.378	72.708	108.361	400	35
15.748	1.181	63.175	94.154	400	30
15.945	1.969	101.023	150.561	405	50
16.142	1.772	93.482	139.322	410	45
16.142	1.575	84.233	125.538	410	40
16.142	1.969	102.446	152.681	410	50
16.142	1.181	64.883	96.698	410	30
16.535	2.756	139.440	207.816	420	70
16.535	1.969	105.292	156.923	420	50
16.535	1.575	86.510	128.931	420	40
16.929	1.181	68.297	101.788	430	30
16.929	1.575	88.787	132.324	430	40
16.929	1.969	108.138	161.164	430	50
16.929	1.772	98.604	146.956	430	45
17.323	1.181	70.005	104.332	440	30
17.323	1.575	91.063	135.717	440	40
17.323	1.969	110.983	165.405	440	50

Imperial Unit		Unit Weight		International Unit	
OD/in	Wall/in	Lbs/FT	Kg/m	OD/mm	Wall/mm
17.717	1.181	71.712	106.877	450	30
17.717	1.575	93.340	139.110	450	40
17.717	1.969	113.829	169.646	450	50
18.110	1.181	73.420	109.422	460	30
18.110	1.575	95.616	142.503	460	40
18.110	1.969	116.675	173.887	460	50
18.110	2.756	155.377	231.567	460	70
18.504	1.181	75.127	111.966	470	30
18.504	1.575	97.893	145.896	470	40
18.504	1.378	86.652	129.143	470	35
18.504	1.969	119.520	178.128	470	50
18.898	1.181	76.835	114.511	480	30
18.898	1.575	100.169	149.288	480	40
18.898	1.969	122.366	182.369	480	50
19.291	1.181	78.542	117.056	490	30
19.291	1.575	102.446	152.681	490	40
19.291	1.969	125.212	186.611	490	50
19.685	1.181	80.249	119.600	500	30
19.685	1.575	104.723	156.074	500	40
19.685	2.362	150.254	223.933	500	60
19.685	1.969	128.058	190.852	500	50
19.685	2.756	171.313	255.317	500	70
20.079	1.181	81.957	122.145	510	30
20.079	1.575	106.999	159.467	510	40
20.079	1.969	130.903	195.093	510	50
20.472	2.756	179.281	267.192	520	70
20.472	2.362	157.084	234.111	520	60

Imperial Unit		Unit Weight		International Unit	
OD/in	Wall/in	Lbs/FT	Kg/m	OD/mm	Wall/mm
20.472	1.969	133.749	199.334	520	50
20.472	1.575	109.276	162.860	520	40
20.472	1.181	83.664	124.690	520	30
20.866	1.575	111.552	166.253	530	40
20.866	1.181	85.372	127.235	530	30
21.260	1.969	139.440	207.816	540	50
21.260	1.575	113.829	169.646	540	40
21.260	1.181	87.079	129.779	540	30
21.260	1.772	126.777	188.943	540	45
21.654	1.969	142.286	212.058	550	50
21.654	1.575	116.106	173.039	550	40
21.654	1.181	88.787	132.324	550	30
22.047	1.969	145.132	216.299	560	50
22.047	1.575	118.382	176.432	560	40
22.047	1.181	90.494	134.869	560	30
22.835	1.969	150.823	224.781	580	50
22.835	1.575	122.935	183.218	580	40
22.835	1.181	93.909	139.958	580	30
23.622	1.969	156.515	233.263	600	50
23.622	1.575	127.488	190.004	600	40
23.622	1.181	97.324	145.047	600	30
24.016	1.969	159.361	237.504	610	50
24.016	1.181	99.031	147.592	610	30
24.409	2.756	219.121	326.569	620	70
24.409	2.165	176.862	263.587	620	55
24.409	1.575	132.042	196.789	620	40
24.409	1.181	100.739	150.137	620	30

Imperial Unit		Unit Weight		International Unit	
OD/in	Wall/in	Lbs/FT	Kg/m	OD/mm	Wall/mm
24.803	2.106	175.540	261.617	630	54
24.803	1.575	134.318	200.182	630	40
24.803	1.181	102.446	152.681	630	30
25.197	1.969	167.898	250.228	640	50
25.197	1.575	136.595	203.575	640	40
25.197	1.181	104.154	155.226	640	30
25.591	2.953	245.444	365.799	650	75
25.591	2.165	186.253	277.583	650	55
25.591	1.969	170.743	254.469	650	50
25.591	1.575	138.871	206.968	650	40
25.591	1.181	105.861	157.771	650	30
27.559	1.181	114.398	170.494	700	30

- Standard aluminum pipe lengths are 2.5m, 3m, 4m, and 6m, with custom lengths up to 15m available.
- We offer cutting, punching, bending, and wall expansion services for all pipes.
- All stock products are available for retail, and orders will be processed and shipped within one week.
- As a one-stop aluminum supplier, we offer discounts for bulk purchases.
- All stock weights are density-based estimates and may differ from actual weights.



Welcome to contact us!

+86 173 4489 4490

sale@chalcoaluminum.com

No. 89, Science Avenue, Zhengzhou
High-Tech Zone, Henan, China